

Tiger-Vac®

...THE NAME TO VACUUM WITH
SINCE 1983

3D PRINTING ADDITIVE MANUFACTURING



TIGER-VAC.COM

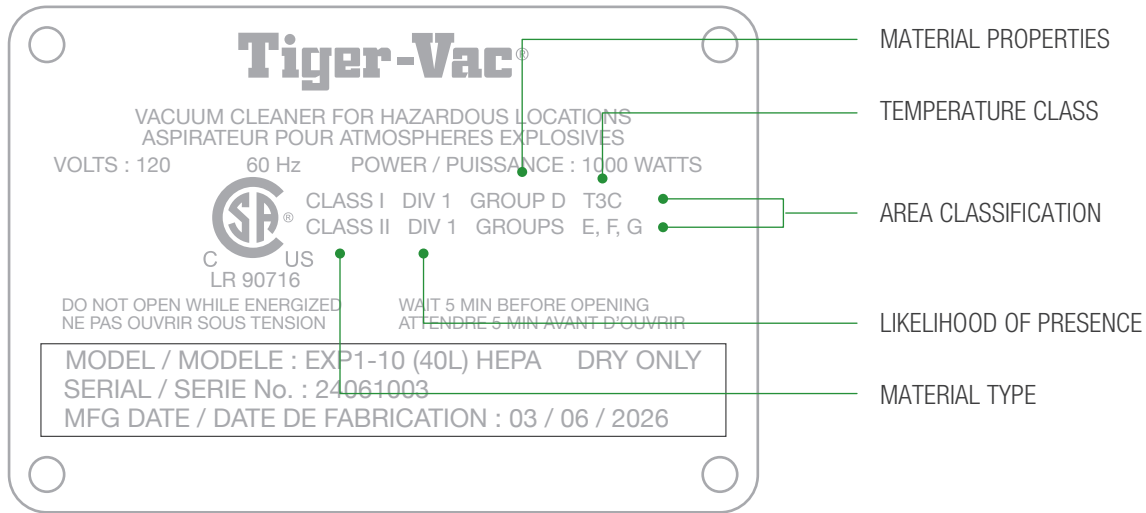

HAZARDOUS LOCATIONS SAFE RECOVERY OF COMBUSTIBLE SUBSTANCES



	SUBSTANCE	SETTING	CLASSIFICATION	VOLATILITY
CLASS I	<ul style="list-style-type: none"> FLAMMABLE GASES VAPORS LIQUIDS 	<ul style="list-style-type: none"> OIL REFINERY PAINT WAREHOUSE SPRAY BOOTH OIL RIG 	Div.1 HAZARD LIKELY	MOST ↑ ↓ LEAST
			Div.2 HAZARD NOT LIKELY	
CLASS II	<ul style="list-style-type: none"> COMBUSTIBLE DUSTS 	<ul style="list-style-type: none"> COAL MINE GRAIN SILO MUNITIONS FACTORY HAY STORAGE 	Div.1 HAZARD LIKELY	
			Div.2 HAZARD NOT LIKELY	
CLASS III	<ul style="list-style-type: none"> IGNITABLE FIBERS FLYINGS 	<ul style="list-style-type: none"> PAPER MILL WOODWORKING TEXTILE MILL COTTON GIN 	Div.1 HAZARD LIKELY	
			Div.2 HAZARD NOT LIKELY	

ORDINARY LOCATION SAFE RECOVERY OF COMBUSTIBLE DUSTS AND FIBERS



	SUBSTANCE	SETTING	CLASSIFICATION	VOLATILITY
ORDLOC NFPA 660	<ul style="list-style-type: none"> COMBUSTIBLE DUSTS FIBERS 	<ul style="list-style-type: none"> INDUSTRIAL 	NO HAZARD	NONE

ORDINARY LOCATIONS SAFE RECOVERY OF NON-COMBUSTIBLE SUBSTANCES



	SUBSTANCE	SETTING	CLASSIFICATION	VOLATILITY
ORDINARY LOCATIONS	<ul style="list-style-type: none"> NON-COMBUSTIBLE 	<ul style="list-style-type: none"> INDUSTRIAL 	NO HAZARD	NONE



PROVEN
SOLUTIONS FOR
SAFE
POWDER
RECOVERY



EFFECTIVELY CLEAN CREVICES AND HARD TO REACH AREAS QUICKLY, SAFELY, AND EFFICIENTLY

COMBUSTIBLE / CONDUCTIVE DUSTS

- Group F** Conductive carbonaceous dust (carbon black, coal, coke dust, etc.)
- Group G** All flour dust (grain, flour, starch, sugar, wood, plastic, chemical dust, etc.)
- Group IIIC** Conductive dust Zone 22 (as per International Standards)

FILTER BLOCKAGE INDICATOR

Indicates loss of suction

**5 Gal.
19 L**

RECOVERY CAPACITY

**SINGLE
PHASE**

**HD | HEAVY
DUTY**

2-STAGE BYPASS MOTOR

Great durability, efficiency, and long lifespan

Brushless Motor ALSO AVAILABLE

4 CLASS H14 HEPA FILTERS

- Filtration efficiency of 99.995% at 0.3 micron
- 21.8 ft² filter surface area

HIGH FILTRATION EFFICIENCY FOR WORKING AIR EXHAUST

STATIC DISSIPATIVE MAIN FILTER

Washable filter

STAINLESS STEEL

Corrosion resistant and easy to decontaminate



CONDUCTIVE POLYLINER

Containment bag for easy disposal



CONDUCTIVE BAGS

(Package of 3)

CONDUCTIVE WHEELS

Prevents static buildup



STATIC DISSIPATIVE 3D TOOLKIT

- Crushproof hose
- Round brush
- Conical nozzle
- Crevice tool

DRY RECOVERY

C-10 EX 4W + 3D TOOLKIT

PART # 111805A-3D

VOLTAGE	120 V	SOUND LEVEL	72 dB(A)
POWER	1.6 HP	VAC. PRESSURE	107 in. H ₂ O
AMPERAGE	10.5 A	WEIGHT	52 lb.
AIR FLOW	110 CFM	CORD LENGTH	35 ft.

FOR COMPLETE SPECIFICATIONS, VISIT THE PRODUCT PAGE | TIGER-VAC.COM



DESIGNED TO THOROUGHLY CLEAN THE BUILD CHAMBER AND PRINT BED

COMBUSTIBLE/CONDUCTIVE DUSTS

- Group F** Conductive carbonaceous dust (carbon black, coal, coke dust, etc.)
- Group G** All flour dust (grain, flour, starch, sugar, wood, plastic, chemical dust, etc.)
- Group IIC** Conductive dust Zone 22 (as per International Standards)

9.2 Gal.
35 L
RECOVERY
CAPACITY

**SINGLE
PHASE**

HD | HEAVY
DUTY

2-STAGE BYPASS MOTOR

Great durability, efficiency, and long lifespan

Brushless Motor ALSO AVAILABLE

4 CLASS H14 HEPA FILTERS

- Filtration efficiency of 99.995% at 0.3 micron
- 21.8 ft² filter surface area

HIGH FILTRATION EFFICIENCY FOR WORKING AIR EXHAUST

STATIC DISSIPATIVE MAIN FILTER

Washable filter

MANUAL FILTER SHAKER

Dislodges caked-on powders

STAINLESS STEEL TYPE 430

Corrosion resistant and easy to decontaminate

ALSO AVAILABLE

CONDUCTIVE POLYLINER

Recovery bag for easy disposal of recovered powders

CONDUCTIVE WHEELS

Prevents static buildup



DETACHABLE TANK

Easy disposal of recovered powders

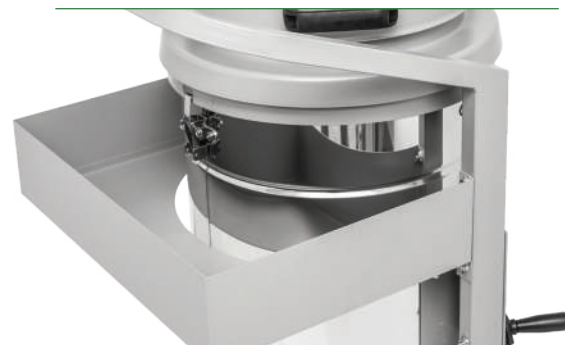

TOOL BASKET

Onboard tool storage for efficient organization and easy access to tools on the go

DRY RECOVERY

C-35L

EX DT MFS + TOOLKIT

PART # 111783A

VOLTAGE	120 V	SOUND LEVEL	72 dB(A)
POWER	1.6 HP	VAC. PRESSURE	107 in. H ₂ O
AMPERAGE	10.5 A	WEIGHT	89 lb.
AIR FLOW	110 CFM	CORD LENGTH	35 ft.

FOR COMPLETE SPECIFICATIONS, VISIT THE PRODUCT PAGE | TIGER-VAC.COM

Div.1
EXPLOSION PROOF /
DUST IGNITION PROOF

3rd
PARTY
CERTIFIED



RECOVER COMBUSTIBLE DUST SAFELY IN HAZARDOUS AREAS

MOST COMPACT UNIT IN THE INDUSTRY

- Conductive inlet port
- Stainless steel 304

SINGLE
PHASE

AMETEK[®]
LONG LIFE MOTORS

**EX PROOF TEFC MOTOR AND
EX PROOF SWITCH BOX**

DRY RECOVERY

EXP1-10 (40L)

HEPA + 3D TOOLKIT PART # 113151A

VOLTAGE	120 V
POWER	1.3 HP
AMPERAGE	9 A
AIR FLOW	132 CFM
VAC. PRESSURE	69 in. H ₂ O
SOUND LEVEL	78-85 dB(A)
CORD LENGTH	50 ft.



CONDUCTIVE POLYLINER
Containment bag for easy disposal



HIGH EFFICIENCY CONDUCTIVE BAGS
Conductive cloth recovery bags

FOR COMPLETE SPECIFICATIONS, VISIT THE PRODUCT PAGE | TIGER-VAC.COM

Div.1
EXPLOSION PROOF /
DUST IGNITION PROOF

3rd
PARTY
CERTIFIED



**COMPRESSED
AIR-OPERATED**



PRESSURE REGULATOR

Adjustable between
0 PSI and 150 PSI

*Factory set at 80 PSI for ideal
performance and noise level*

SINGLE
VENTURI

DRY RECOVERY

ATEX-10A (40L)

HEPA + 3D TOOLKIT PART # 113115

MIN. COMPRESSOR	15 HP
AIR LINE (Diam.)	0.5 in.
AIR VOLUME	34-45 CFM
AIR PRESSURE	80 PSI
AIR FLOW	110 CFM
VAC. PRESSURE	110 in. H ₂ O
SOUND LEVEL	68 dB(A)



CONDUCTIVE POLYLINER
Containment bag for easy disposal



HIGH EFFICIENCY CONDUCTIVE BAGS
Conductive cloth recovery bags

FOR COMPLETE SPECIFICATIONS, VISIT THE PRODUCT PAGE | TIGER-VAC.COM



DESIGNED TO RECOVER
COMBUSTIBLE DUST AND NON-COMBUSTIBLE DUST
 REDUCE COST BY REUSING UP TO **98%** OF THE RECOVERED POWDERS



SHOWN WITH MODEL
EXP1-10 (40L)

METAL DUST
 RECOVERY OF NON-REACTIVE METAL
 AND COMBUSTIBLE DUST

HIGH EFFICIENCY CYCLONE

HEC-25L

4W SS 304 PART # 112311

SUCTION INLET	1.5 in.
AIR OUTLET	1.5 in.
REC. CAPACITY	6.6 Gal. (25 L)

FOR COMPLETE SPECIFICATIONS,
 VISIT THE PRODUCT PAGE
TIGER-VAC.COM



SHOWN WITH MODEL
C-10 EX (4W)



PLASTIC DUST
 STATIC DISSIPATIVE
 AND GROUNDED

HIGH EFFICIENCY CYCLONE

HEC-35L

4W SS 430 PART # 112309

SUCTION INLET	2 in.
AIR OUTLET	1.5 in.
REC. CAPACITY	9 Gal. (35 L)

FOR COMPLETE SPECIFICATIONS,
 VISIT THE PRODUCT PAGE
TIGER-VAC.COM



RECOVER. RESIZE. REFRESH. REUSE
REUSE UP TO 98% OF THE RECOVERED POWDER
 SUITABLE FOR ALL AM APPLICATIONS, BOTH PLASTIC DUST AND METAL DUST



6.6 Gal. 25 L
 RECOVERY CAPACITY

POWDER RECOVERY SYSTEM
 AND HIGH EFFICIENCY CYCLONE

EXP1-20
DT (PRS-HEC) RE HEPA + 3D TOOLKIT

PART # 113220A-3D

VOLTAGE	120 V	VAC. PRESSURE	69 in. H ₂ O
POWER	1.3 HP	SOUND LEVEL	78-85 dB(A)
AMPERAGE	9 A	WEIGHT	216 lb.
AIR FLOW	132 CFM	CORD LENGTH	50 ft.

FOR COMPLETE SPECIFICATIONS, VISIT THE PRODUCT PAGE | TIGER-VAC.COM

HEPA FILTER

Filtration efficiency of 99.995%
 at 0.3 micron

**SINGLE
 PHASE**



**EX PROOF TEFC MOTOR AND
 EX PROOF SWITCH BOX**

Quiet operation, low maintenance,
 and long lifespan

STAINLESS STEEL TYPE 304

Corrosion resistant and easy to decontaminate

CYCLONIC PRE-SEPARATOR

Separate and collect up to 98% of the powder
 before it enters the vacuum system

DETACHABLE TANK

- Very high protection level
- Easy disposal of recovered powders

CONDUCTIVE WHEELS

Prevents static buildup



**COMPRESSED
 AIR-OPERATED**



PNEUMATIC HEAD ALSO AVAILABLE

Model SS-20 DT (PRS-HEC) RE HEPA,
 with a filtration efficiency of 99.995% at 0.3 micron



RECOVER. RESIZE. REFRESH. REUSE
REUSE UP TO 98% OF THE RECOVERED POWDER
 SUITABLE FOR ALL AM APPLICATIONS, BOTH PLASTIC DUST AND METAL DUST



6.6 Gal. 25 L
 RECOVERY CAPACITY

POWDER RECOVERY SYSTEM
 AND HIGH EFFICIENCY CYCLONE

C-10 EX

DT (PRS-HEC) HEPA + 3D TOOLKIT

PART # 113230A-3D

VOLTAGE	120 V	VAC. PRESSURE	107 in. H ₂ O
POWER	1.6 HP	SOUND LEVEL	72 dB(A)
AMPERAGE	10.5 A	WEIGHT	216 lb.
AIR FLOW	110 CFM	CORD LENGTH	50 ft.

FOR COMPLETE SPECIFICATIONS, VISIT THE PRODUCT PAGE | TIGER-VAC.COM

SINGLE PHASE

HD | HEAVY DUTY

2-STAGE BYPASS MOTOR

Great durability, efficiency, and long lifespan

Brushless Motor ALSO AVAILABLE

4 CLASS H14 HEPA FILTERS

- Filtration efficiency of 99.995% at 0.3 micron
- 21.8 ft² filter surface area

HIGH FILTRATION EFFICIENCY FOR WORKING AIR EXHAUST

STAINLESS STEEL TYPE 304

Corrosion resistant and easy to decontaminate

CYCLONIC PRE-SEPARATOR

Separate and collect up to 98% of the powder before it enters the vacuum system

DETACHABLE TANK

- Very high protection level
- Easy disposal of recovered powders

CONDUCTIVE WHEELS

Prevents static buildup



STATIC DISSIPATIVE 3D TOOLKIT

- Crushproof hose
- Round brush
- Conical nozzle
- Crevice tool

Div.2
DUST IGNITION
PROTECTED

3rd
PARTY
CERTIFIED

DESIGNED TO RECOVER AND NEUTRALIZE CONDUCTIVE POWDERS

DUST
11 lb
5 kg
RECOVERY
CAPACITY

6.5 Gal.
25 L
NEUTRALIZING
LIQUID

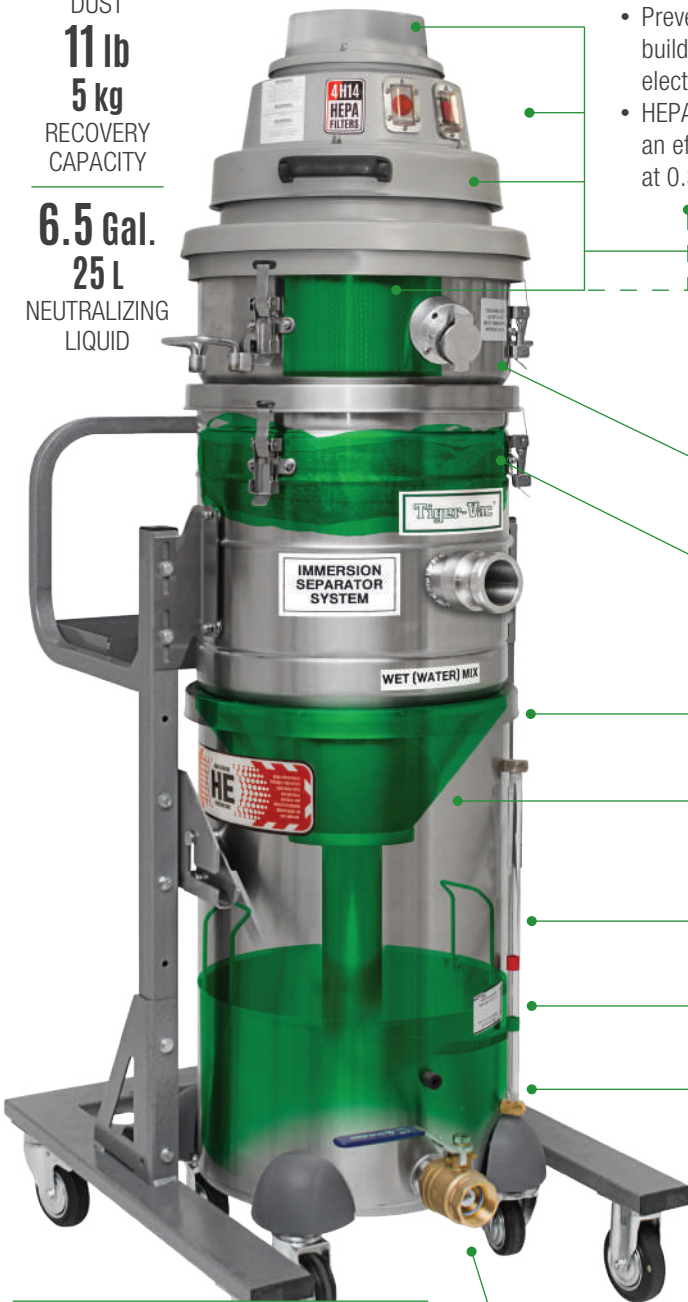

COALESCING FILTER ELEMENT

- Prevents moisture buildup from damaging electrical components
- HEPA grade with an efficiency of 99.97% at 0.3 micron

**SINGLE
PHASE**

HD | HEAVY
DUTY

2-STAGE BYPASS MOTOR

Great durability, efficiency, and long lifespan

Brushless Motor ALSO AVAILABLE

4 CLASS H14 HEPA FILTERS

- Filtration efficiency of 99.995% at 0.3 micron
- 21.8 ft² filter surface area

HIGH FILTRATION EFFICIENCY FOR WORKING AIR EXHAUST

DEGASSING VENT

Vents potentially hazardous gas buildup inside the vacuum

MIST ARRESTOR

Removes contaminants from process air emissions that evolve as mist droplets

STAINLESS STEEL TYPE 304

Corrosion resistant and easy to decontaminate

SEPARATOR CONE

Prevents droplets and dust from reaching the motor

DETACHABLE TANK

Easy access to recovered powders

LIQUID LEVEL INDICATOR

Impact-resistant polycarbonate

SIEVE BASKET

Separates the sludge from the neutralizing liquid

IMMERSION SEPARATOR

C-10 EX (IT-63L)

CFE HEPA + 3D TOOLKIT PART # 113172A-3D

DRAIN VALVE 38 mm

With locking system to prevent accidental spills



MIST ARRESTOR

Removes contaminants from process air emissions that evolve as mist droplets

VOLTAGE	120 V	SOUND LEVEL	72 dB(A)
POWER	1.6 HP	VAC. PRESSURE	107 in. H ₂ O
AMPERAGE	10.5 A	HEIGHT	63 in.
AIR FLOW	110 CFM	CORD LENGTH	35 ft.

FOR COMPLETE SPECIFICATIONS, VISIT THE PRODUCT PAGE | TIGER-VAC.COM



DESIGNED TO RECOVER AND NEUTRALIZE COMBUSTIBLE DUST

OIL | HYDROGEN FREE WITH MINERAL OIL

STAINLESS STEEL TYPE 304

Corrosion resistant and easy to decontaminate

COALESCING FILTER ELEMENT

- Prevents moisture buildup from damaging electrical components
- HEPA grade with an efficiency of 99.97% at 0.3 micron

SINGLE PHASE

HD | HEAVY DUTY

2-STAGE BYPASS MOTOR

Great durability, efficiency, and long lifespan

Brushless Motor ALSO AVAILABLE

4 CLASS H14 HEPA FILTERS

- Filtration efficiency of 99.995% at 0.3 micron
- 21.8 ft² filter surface area

HIGH FILTRATION EFFICIENCY FOR WORKING AIR EXHAUST

DEGASSING VENT

Vents potentially hazardous gas buildup inside the vacuum

MIST ARRESTOR

Removes contaminants from process air emissions that evolve as mist droplets

MIST ARRESTOR

Aluminum mesh screen prevents mist droplets from reaching the motor

DETACHABLE TANK

Easy access to recovered powders

LIQUID LEVEL INDICATOR

Impact-resistant

1.5 Gal.
4.5 L
RECOVERY CAPACITY



IMMERSION SEPARATOR

C-10 EX (IT-40L)

DT CFE HEPA + 3D TOOLKIT

PART # 113179A-3D

VOLTAGE	120 V	SOUND LEVEL	72 dB(A)
POWER	1.6 HP	VAC. PRESSURE	107 in. H ₂ O
AMPERAGE	10.5 A	WEIGHT	92 lb.
AIR FLOW	110 CFM	CORD LENGTH	35 ft.



STATIC DISSIPATIVE 3D TOOLKIT

- Crushproof hose
- Conical nozzle
- Round brush
- Crevice tool



DEPRESSOR CAGE

Keeps the conductive collection bag submerged

FOR COMPLETE SPECIFICATIONS, VISIT THE PRODUCT PAGE | TIGER-VAC.COM



DESIGNED TO RECOVER AND NEUTRALIZE COMBUSTIBLE DUST

OIL | HYDROGEN FREE WITH MINERAL OIL

STAINLESS STEEL TYPE 304

Corrosion resistant and easy to decontaminate



**1.5 Gal.
4.5 L**
RECOVERY CAPACITY

SINGLE PHASE



EX PROOF TEFC MOTOR AND EX PROOF SWITCH BOX

Quiet operation, low maintenance, and long lifespan

COALESCING FILTER ELEMENT

- Prevents moisture buildup from damaging electrical components
- HEPA grade with an efficiency of 99.97% at 0.3 micron

DEGASSING VENT

Vents potentially hazardous gas buildup inside the vacuum

MIST ARRESTOR

Removes contaminants from process air emissions that evolve as mist droplets

MIST ARRESTOR

Aluminum mesh screen prevents mist droplets from reaching the motor

DETACHABLE TANK

Easy access to recovered powders

LIQUID LEVEL INDICATOR

Impact-resistant

IMMERSION SEPARATOR

EXP1-10 (IT-40L)

EX DT CFE HEPA + 3D TOOLKIT PART # 113153A-3D

VOLTAGE	120 V	SOUND LEVEL	78-85 dB(A)
POWER	1.3 HP	VAC. PRESSURE	69 in. H ₂ O
AMPERAGE	9 A	WEIGHT	94 lb.
AIR FLOW	132 CFM	CORD LENGTH	50 ft.



STATIC DISSIPATIVE 3D TOOLKIT

- Crushproof hose
- Conical nozzle
- Round brush
- Crevice tool



DEPRESSOR CAGE

Keeps the conductive collection bag submerged



DESIGNED TO RECOVER AND NEUTRALIZE COMBUSTIBLE DUST



OIL

HYDROGEN FREE
WITH MINERAL OIL



WATER

HYDROGEN SAFE
WITH WATER (NO OIL)

STAINLESS STEEL TYPE 304

Corrosion resistant and easy to decontaminate

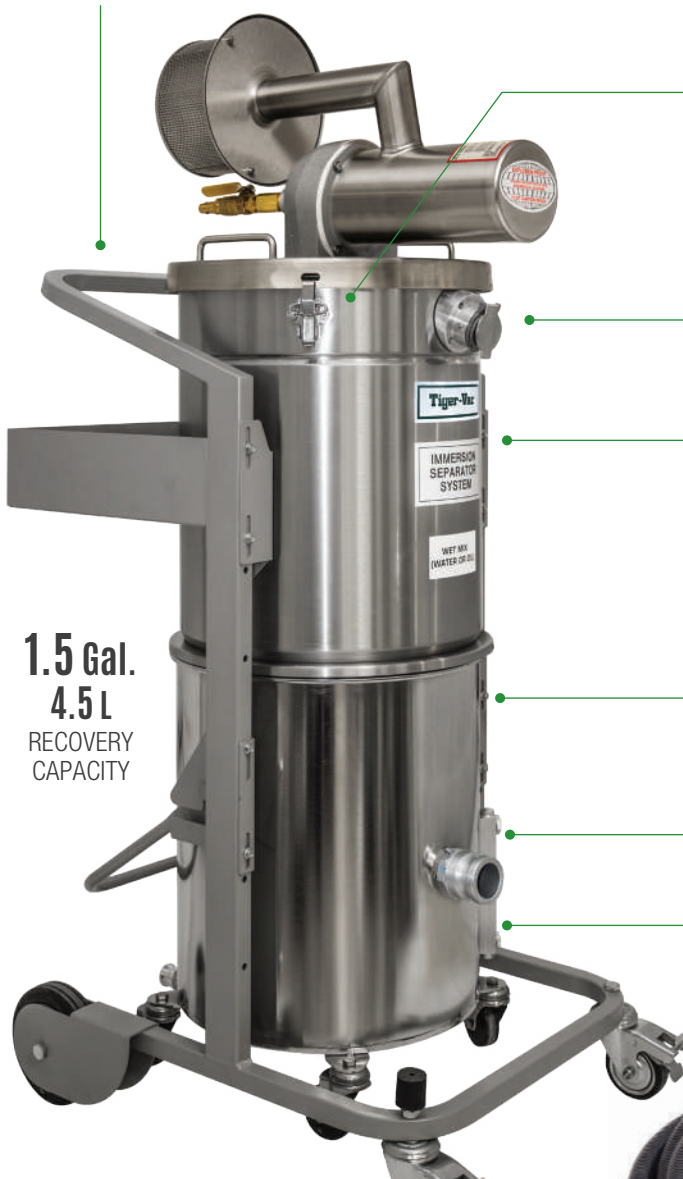

**1.5 Gal.
4.5 L**
RECOVERY
CAPACITY

**SINGLE
VENTURI**

COALESCING FILTER ELEMENT

- Prevents moisture buildup from damaging electrical components
- HEPA grade with an efficiency of 99.97% at 0.3 micron

DEGASSING VENT

Vents potentially hazardous gas buildup inside the vacuum

MIST ARRESTOR

Removes contaminants from process air emissions that evolve as mist droplets

MIST ARRESTOR

Aluminum mesh screen prevents mist droplets from reaching the motor

DETACHABLE TANK

Easy access to recovered powders

LIQUID LEVEL INDICATOR

Impact-resistant

IMMERSION SEPARATOR

SS-10 (IT-40L)

DT RE HEPA + 3D TOOLKIT PART # 113119-3D

MIN. COMPRESSOR	15 HP	AIR FLOW	125 CFM
AIR LINE (Diam.)	0.5 in.	VAC. PRESSURE	110 in. H ₂ O
AIR VOLUME	45 CFM	SOUND LEVEL	72 dB(A)
AIR PRESSURE	80 PSI	WEIGHT	105 lb.



STATIC DISSIPATIVE 3D TOOLKIT

- Crushproof hose
- Conical nozzle
- Round brush
- Crevice tool



DEPRESSOR CAGE

Keeps the conductive collection bag submerged

FOR COMPLETE SPECIFICATIONS, VISIT THE PRODUCT PAGE | TIGER-VAC.COM



DESIGNED TO RECOVER AND NEUTRALIZE COMBUSTIBLE DUST

WET BAG
0.8 Gal.
3 L
 RECOVERY CAPACITY

3.25 Gal.
12.3 L
 NEUTRALIZING LIQUID

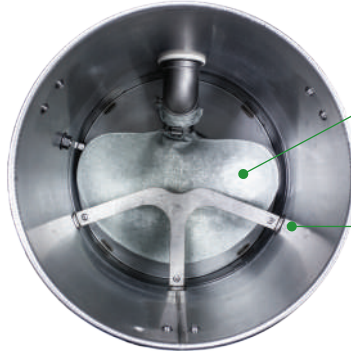

CONDUCTIVE WET BAG

For easy disposal of collected dust

COLLECTION BAG RETAINER

Keeps the conductive bag submerged

COALESCING FILTER ELEMENT

- Prevents moisture buildup from damaging electrical components
- HEPA grade with an efficiency of 99.97% at 0.3 micron

SINGLE PHASE

HD | HEAVY DUTY

2-STAGE BYPASS MOTOR

Great durability, efficiency, and long lifespan

Brushless Motor ALSO AVAILABLE

4 CLASS H14 HEPA FILTERS

- Filtration efficiency of 99.995% at 0.3 micron
- 21.8 ft² filter surface area

HIGH FILTRATION EFFICIENCY FOR WORKING AIR EXHAUST

STAINLESS STEEL TYPE 304

Corrosion resistant and easy to decontaminate

LIQUID LEVEL INDICATOR

Impact-resistant



IMMERSION SEPARATOR

C-10 EX (IT-40L)

CFE HEPA + 3D TOOLKIT PART # 113178A-3D

VOLTAGE	120 V	SOUND LEVEL	72 dB(A)
POWER	1.6 HP	VAC. PRESSURE	107 in. H ₂ O
AMPERAGE	10.5 A	WEIGHT	62 lb.
AIR FLOW	110 CFM	CORD LENGTH	35 ft.



STATIC DISSIPATIVE TOOLKIT

- Crushproof hose
- Round brush
- Conical nozzle
- Crevice tool

FOR COMPLETE SPECIFICATIONS, VISIT THE PRODUCT PAGE | TIGER-VAC.COM



DESIGNED TO RECOVER AND NEUTRALIZE COMBUSTIBLE DUST

WET BAG
0.8 Gal.
3 L
 RECOVERY
 CAPACITY

3.25 Gal.
12.3 L
 NEUTRALIZING
 LIQUID

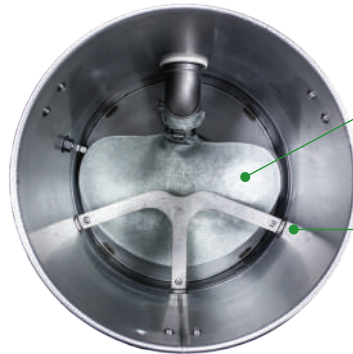

CONDUCTIVE WET BAG

For easy disposal of collected dust

COLLECTION BAG RETAINER

Keeps the conductive bag submerged

SINGLE
 PHASE



Ex PROOF TEFC MOTOR AND Ex PROOF SWITCH BOX

Quiet operation, low maintenance, and long lifespan

COALESCING FILTER ELEMENT

- Prevents moisture buildup from damaging electrical components
- HEPA grade with an efficiency of 99.97% at 0.3 micron

STAINLESS STEEL TYPE 304

Corrosion resistant and easy to decontaminate

LIQUID LEVEL INDICATOR

Impact-resistant



WET RECOVERY

IMMERSION SEPARATOR

EXP1-10 (IT-40L)

EX CFE HEPA + 3D TOOLKIT

PART # 113152A-3D

VOLTAGE	120 V	SOUND LEVEL	78-85 dB(A)
POWER	1.3 HP	VAC. PRESSURE	69 in. H ₂ O
AMPERAGE	9 A	WEIGHT	70 lb.
AIR FLOW	132 CFM	CORD LENGTH	50 ft.



STATIC DISSIPATIVE TOOLKIT

- Crushproof hose
- Round brush
- Conical nozzle
- Crevice tool

FOR COMPLETE SPECIFICATIONS, VISIT THE PRODUCT PAGE | TIGER-VAC.COM



DESIGNED TO RECOVER AND NEUTRALIZE METAL AND EXPLOSIVE DUST

OIL | HYDROGEN FREE
WITH MINERAL OIL

DUST
22 lb
10 kg
RECOVERY CAPACITY

7.9 Gal.
30 L
NEUTRALIZING LIQUID

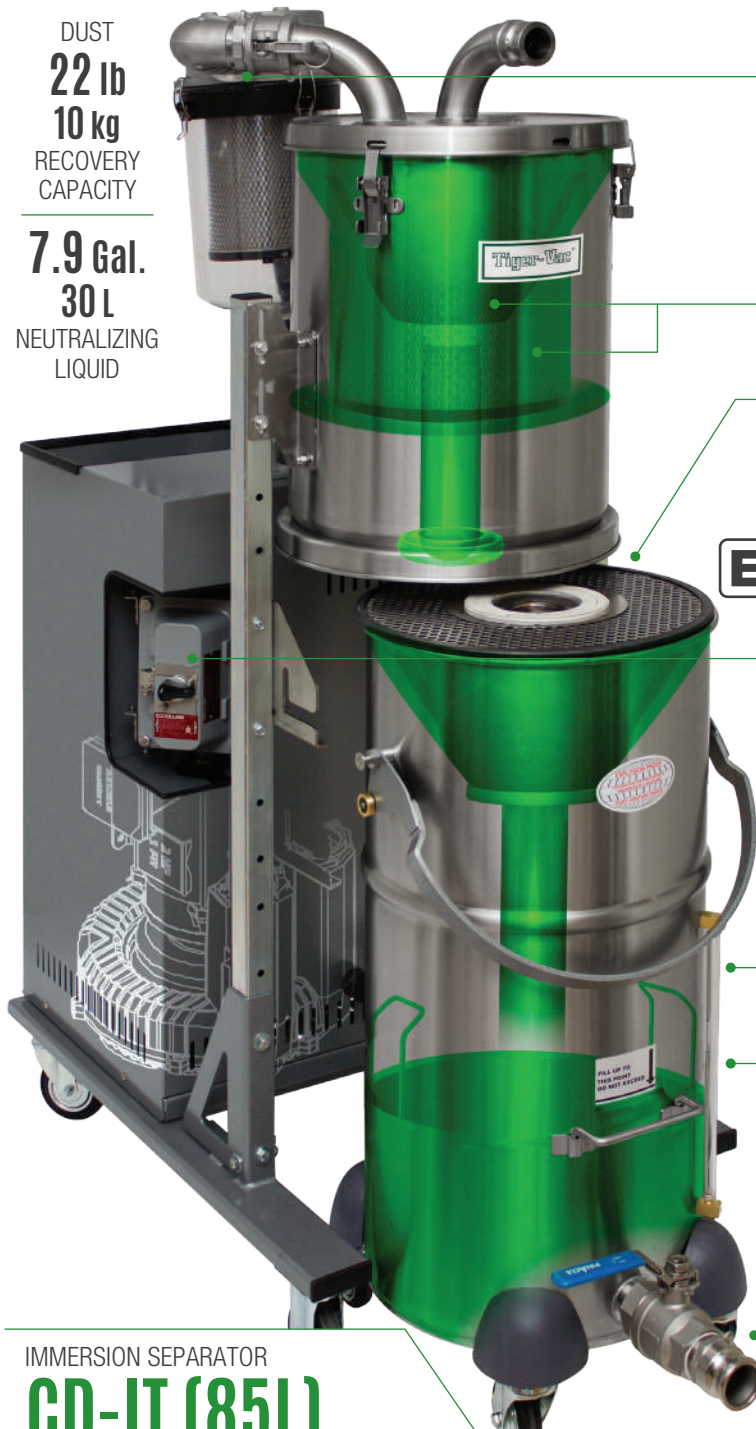

COALESCING FILTER ELEMENT

- Prevents moisture buildup from damaging electrical components
- HEPA grade with an efficiency of 99.97% at 0.3 micron

UPPER CONE + CYLINDER

Prevents mist buildup from reaching the motor

SEPARATOR CONE

Prevents droplets and dust from reaching the motor



EX PROOF REGENERATIVE BLOWER AND EX PROOF SWITCH BOX

Quiet operation, low maintenance, and energy efficient

STAINLESS STEEL TYPE 304

Corrosion resistant and easy to decontaminate

LIQUID LEVEL INDICATOR

Impact-resistant polycarbonate

SIEVE BASKET

Separates the sludge from the neutralizing liquid

DRAIN VALVE 38 mm

With locking system to prevent accidental spills



COALESCING FILTER ELEMENT

Prevents moisture from entering and damaging the motor

IMMERSION SEPARATOR
CD-IT (85L)
EX CFE HEPA PART # 111129A3



VOLTAGE	120 to 460 V	SOUND LEVEL	74 dB(A)
POWER	1.5 to 2 HP	VAC. PRESSURE	120 to 130 in. H ₂ O
AMPERAGE	2.1 to 15 A	WEIGHT	245 lb.
AIR FLOW	125 to 158 CFM	CORD LENGTH	50 ft.

FOR COMPLETE SPECIFICATIONS, VISIT THE PRODUCT PAGE | TIGER-VAC.COM



SAFE RECOVERY OF POWDERS IN THE DEPOWDERING STATION DURING POST-PROCESSING

OPERATE WITHOUT INTERRUPTIONS

- Filter pulse cleaning by compressed air
- Automatic timer continuously purges filter to maintain maximum performance

CONDUCTIVE THERMOPLASTIC RUBBER HOSE DISSIPATES STATIC BUILDUP

- External abrasion and drag resistance
- Great moisture & UV resistance
- Excellent chemical resistance
- Minimal friction loss and efficient air flow

**2.6 Gal.
10 L**
RECOVERY CAPACITY



**1200 CFM
(2000 m³/h)**



**THREE
PHASE**



Ex PROOF REGENERATIVE BLOWER AND Ex PROOF SWITCH BOX

Quiet operation, low maintenance, and energy efficient

FILTER CARTRIDGE

Aluminized spun bond conductive cartridge with an efficiency of 97% at 0.3 micron

ALSO AVAILABLE

Hemipleat® extreme flame retardant conductive cartridge with carbon, with an efficiency of 99.99% at 0.5 micron

STAINLESS STEEL TYPE 304

- Corrosion resistant and easy to decontaminate
- Conductive paint also available

DUST COLLECTOR
CD-1200
EX SS PART # 113044A1



VOLTAGE	230 to 575 V	SOUND LEVEL	74 dB(A)
POWER	5 HP	SUCTION INLET	8 in.
AMPERAGE	5 to 12 A	WEIGHT	473 lb.
AIR FLOW	1200 CFM	CORD LENGTH	50 ft.

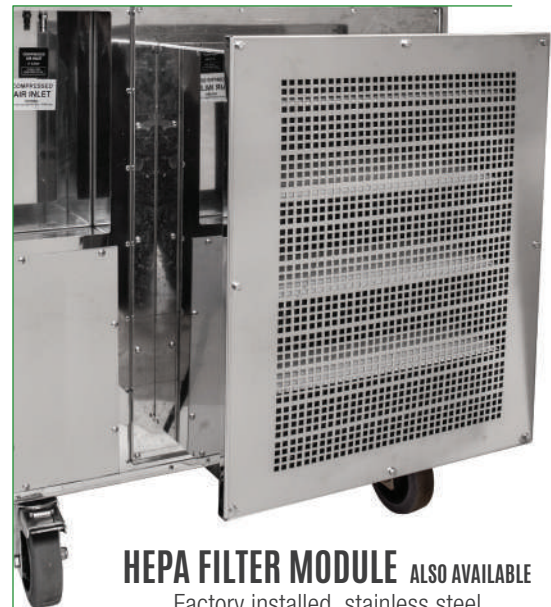

HEPA FILTER MODULE ALSO AVAILABLE

Factory installed, stainless steel downstream HEPA filter module



HEPA FILTER

Filtration efficiency of 99.99% at 0.3 micron



DESIGNED TO SAFELY CAPTURE FUGITIVE AIRBORNE DUST

OPERATE WITHOUT INTERRUPTIONS

- Filter pulse cleaning by compressed air
- Automatic timer continuously purges filter to maintain maximum performance

EXTRACTION ARM

- 6 in. (150 mm) suction inlet
- 6.6 ft. or 10 ft. reach

600-700 CFM
(1020-1190 m³/h)

ALSO AVAILABLE



EX PROOF REGENERATIVE BLOWER AND EX PROOF SWITCH BOX

Quiet operation, low maintenance, and energy efficient

STAINLESS STEEL TYPE 304

Corrosion resistant and easy to decontaminate

FILTER CARTRIDGE

Aluminized spun bond conductive cartridge with an efficiency of 97% at 0.3 micron

ALSO AVAILABLE

Hemipleat® extreme flame retardant conductive cartridge with carbon, with an efficiency of 99.99% at 0.5 micron

2.6 Gal.
10 L
RECOVERY CAPACITY

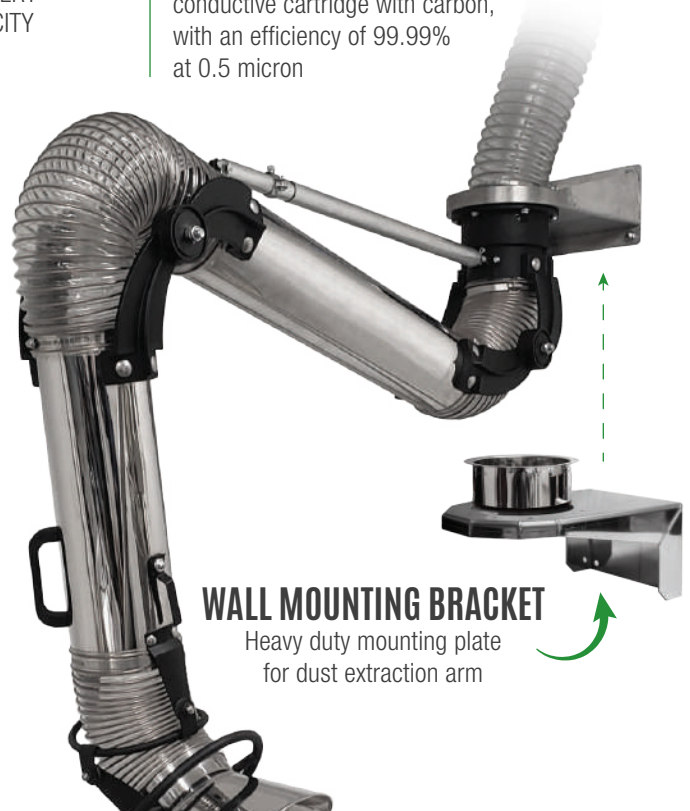

WALL MOUNTING BRACKET

Heavy duty mounting plate for dust extraction arm

DUST COLLECTOR

CD-600

EX HEPA SS

PART # 113003A3



VOLTAGE	120 to 575 V	SOUND LEVEL	72 dB(A)
POWER	1.5 to 2 HP	SUCTION INLET	6 in.
AMPERAGE	2.3 to 15 A	WEIGHT	353 lb.
AIR FLOW	600-700 CFM	CORD LENGTH	50 ft.

FOR COMPLETE SPECIFICATIONS, VISIT THE PRODUCT PAGE | TIGER-VAC.COM



CAPTURE, CONTAIN, AND CONTROL DUST AT THE SOURCE

OPERATE WITHOUT INTERRUPTIONS

- Filter pulse cleaning by compressed air
- Automatic timer continuously purges filter to maintain maximum performance

2 EXTRACTION ARMS

- 6 in. (150 mm) suction inlet
- 6.6 ft. or 10 ft. reach

ALSO AVAILABLE : 1 EXTRACTION ARM

- 8 in. (200 mm) suction inlet
- 6.6 ft. or 10 ft. reach

ALSO AVAILABLE

1200 CFM
(2000 m³/h)



THREE PHASE



EX PROOF REGENERATIVE BLOWER AND EX PROOF SWITCH BOX

Quiet operation, low maintenance, and energy efficient

2.6 Gal.
10 L

RECOVERY CAPACITY

FILTER CARTRIDGE

Aluminized spun bond conductive cartridge with an efficiency of 97% at 0.3 micron

ALSO AVAILABLE

Hemipleat® extreme flame retardant conductive cartridge with carbon, with an efficiency of 99.99% at 0.5 micron

STAINLESS STEEL TYPE 304

- Corrosion resistant and easy to decontaminate
- Conductive paint also available



DUST COLLECTOR

CD-1200

EX SS PART # 113044A1



VOLTAGE	230 to 575 V	SOUND LEVEL	74 dB(A)
POWER	5 HP	SUCTION INLET	6 in.
AMPERAGE	5 to 12 A	WEIGHT	473 lb.
AIR FLOW	1200 CFM	CORD LENGTH	50 ft.

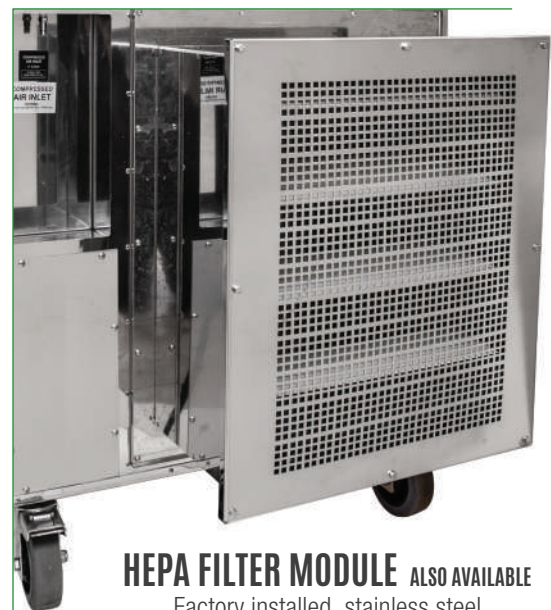

HEPA FILTER MODULE ALSO AVAILABLE

Factory installed, stainless steel downstream HEPA filter module

FOR COMPLETE SPECIFICATIONS, VISIT THE PRODUCT PAGE | TIGER-VAC.COM

Tiger-Vac®

...THE NAME TO VACUUM WITH
SINCE 1983



Tiger-Vac International Inc.
2020 Boul. Dagenais Ouest
Laval, Québec
Canada H7L 5W2

T. 450-625-0099
T. 450-622-0100
F. 450-625-3388
E. sales@tiger-vac.com
W. tiger-vac.com

Tiger-Vac Inc.
11 SW 12th Ave #112
Dania, FL 33004
USA

T. 954-925-3625
F. 954-925-3626
E. sales@tiger-vac.com
W. tiger-vac.com

Tiger-Vac Europa S.R.L.
Via Marie Curie 17
Zona Industriale Ponte Rizzoli
Ozzano Emilia, BO 40064

T. (39) 051 79.53.52
T. (39) 051 4695077
E. info@tiger-vac.it
W. tiger-vac.eu